

ART.-NR. 136600			WERKSTOFF:		ENTGRATEN UND SCHARFE KANTEN BRECHEN	
GEZEICHNET	NAME	DATUM	OBERFLÄCHE	BENENNUNG:		
GEPRÜFT			58.18 m ²	EURO-Jabelmann Wiege-Verpackungs-Automat WVA 660 touch screen		
Letzte Änderung			GEWICHT			
Rev.	Datum	Name	99.93 kg	ZEICHNUNGSNR.	WVA 660	
			STATUS In Änderung		C	
			 Wilsumer Straße 33, 49847 Itterbeck Tel. 05948/9326990 Fax 05948/93269929		MASSSTAB: 1:15	ZEICHNUNG NICHT SKALIEREN
					BLATT 1 VON 2	Format A3

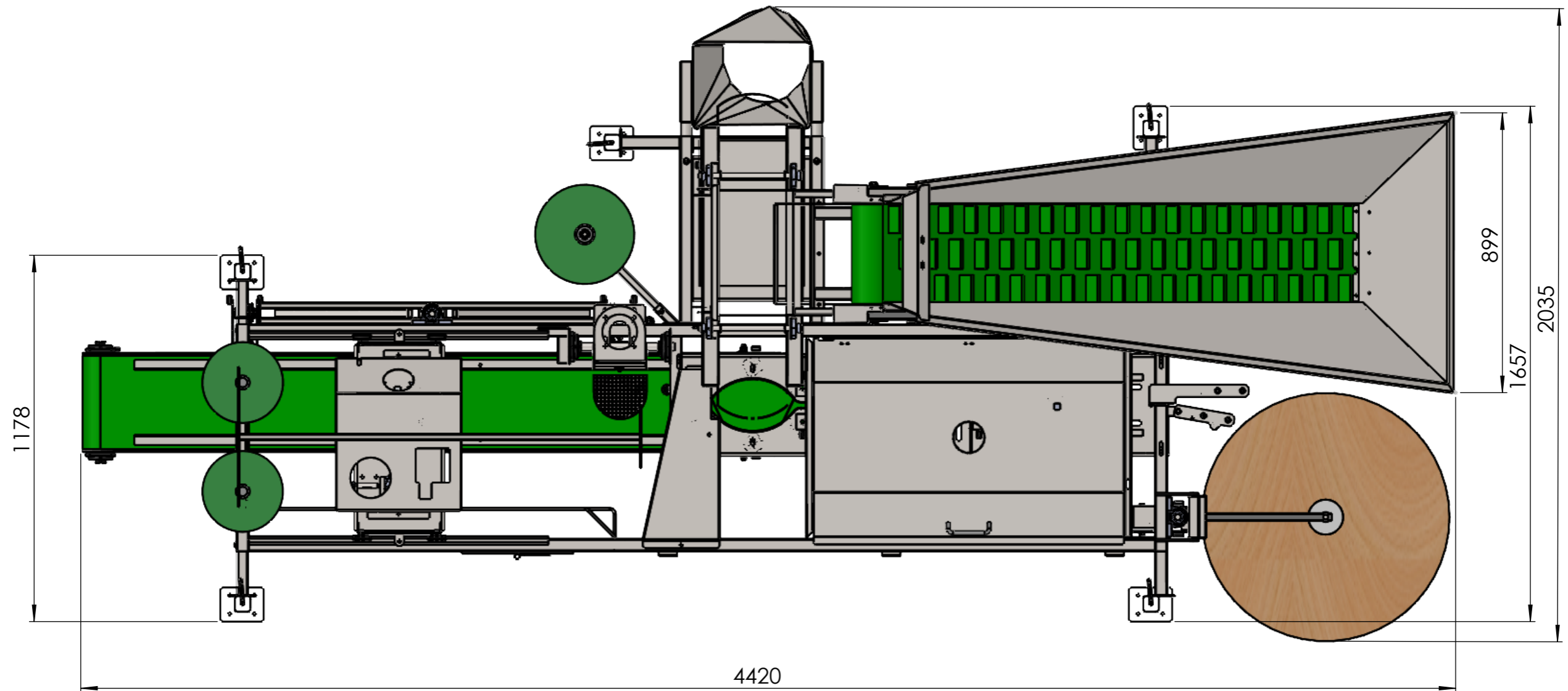

ART.-NR. 136600		WERKSTOFF:		ENTGRATEN UND SCHARFE KANTEN BRECHEN
NAME	DATUM	OBERFLÄCHE	Allgemeintoleranzen DIN ISO 2768-m	BENENNUNG: EURO-Jabelmann Wiege- Verpackungs-Automat WVA 660 touch screen
GEZEICHNET		58.18 m ²		
GEPRÜFT		GEWICHT	Schutzvermerk: DIN ISO 16016:2017-08	ZEICHNUNGSNR. WVA 660
Letzte Änderung		99.93 kg		
Rev.	Datum	Name	STATUS In Änderung	C
 Wilsmer Straße 19-21, 49847 Ifterbeck Tel. 05948/9339-0 Fax 05948/9339-25			MASSSTAB: 1:15	BLATT 2 VON 2
				Format A3